

# WASHERS, CAPS & NUTS

## SQUARE INSULATION WASHERS - SELF LOCKING

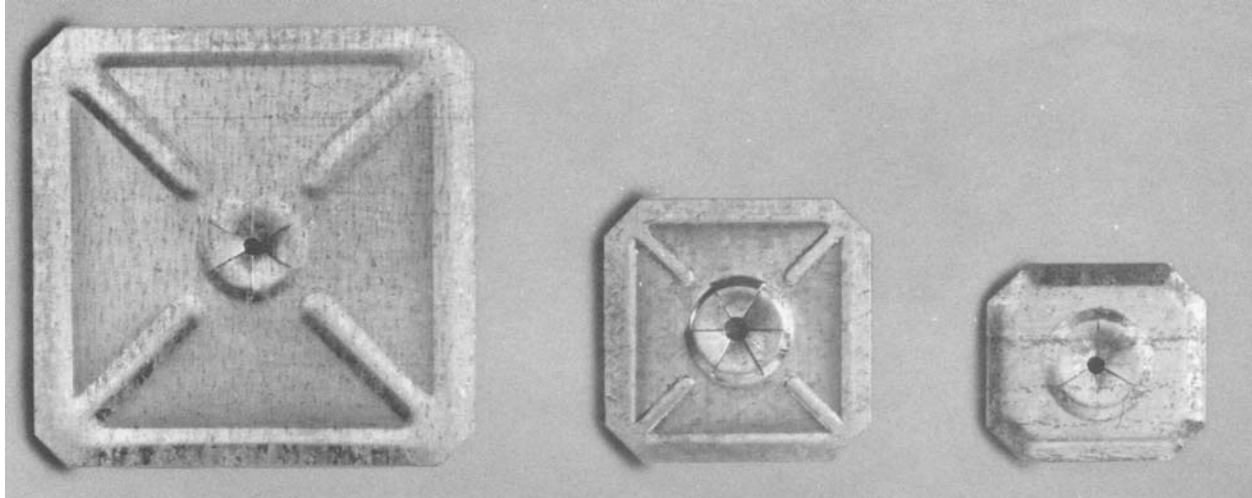

**K250**

**K150S**

**K125**

<b>TYPE</b>	<b>K250</b>	<b>K150S</b>	<b>K125</b>
DIMENSIONS	2-1/2" X 2-1/2"	1-1/2" X 1-1/2"	1-1/4" X 1-1/8"
THICKNESS	.015 NOM	.015 NOM	.015 NOM
MATERIALS	MILD STEEL (GALVANIZED), STAINLESS STEEL, OR ALUMINUM		
EDGES	BEVELED	BEVELED	BEVELED
PACKAGING	1M	1M OR 3M	1M
SHIPPING WEIGHT PER 1000	28-1/2 POUNDS	10 POUNDS	6 POUNDS

HANLON EQUIPMENT Self-Locking Washers are used in conjunction with weld pin, insul-anchors and lacing anchors to fasten insulation in place. Simply press the self-locking washer onto the pin up against the insulation until the desired position is reached and then clip off, or bend over, the remaining portions of pin for permanent attachment.

The choice between Round or Square self-locking washers is basically a matter of aesthetics or personal preference. The domed, multi-lanced hole design provides for ease of locating washer on pin and positive self-locking. Some styles of washers are manufactured with a beveled edge to prevent the washer from cutting into the insulation facing.

Self-Locking Washers are available according to the chart above and with standard 10 GA, 12 GA, or 14 GA hole sizes off-the-shelf. Other material/plating combinations and hole sizes are available by special order.

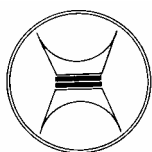

HANLON EQUIPMENT COMPANY  
800 TOUHY AVENUE  
ELK GROVE VILLAGE, ILLINOIS 60007  
PHONE: 847.228.1990 Toll Free: 1-800-HANLONS 426-5667  
FAX: 847.228.1995  
INTERNET: hanlonequipment.com



# WASHERS, CAPS & NUTS

## ROUND INSULATION WASHERS - SELF LOCKING

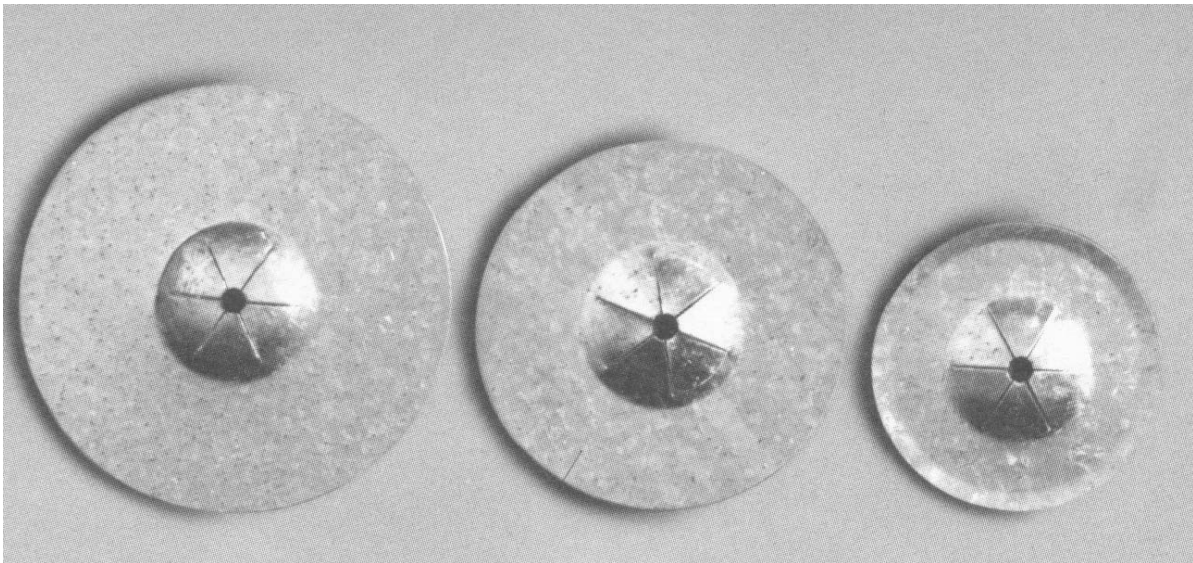

K150

K120

K100

TYPE	150	120	100
DIAMETER	1-1/2"	1-3/16"	1"
THICKNESS	.015 NOM	.015 NOM	.015 NOM
MATERIALS	MILD STEEL (GALVANIZED), STAINLESS STEEL, OR ALUMINUM		
EDGES	FLAT	FLAT	BEVELED
PACKAGING	1M	1M OR 3M	1M
SHIPPING WEIGHT PER 1000	28-1/2 POUNDS	10 POUNDS	6 POUNDS

HANLON EQUIPMENT Self-Locking Washers are used in conjunction with weld pin, insul-anchors and lacing anchors to fasten insulation in place. Simply press the self-locking washer onto the pin up against the insulation until the desired position is reached and then clip off, or bend over, the remaining portions of pin for permanent attachment.

The choice between Round or Square self-locking washers is basically a matter of aesthetics or personal preference. The domed, multi-lanced hole design provides for ease of locating washer on pin and positive self-locking. Some styles of washers are manufactured with a beveled edge to prevent the washer from cutting into the insulation facing.

Self-Locking Washers are available according to the chart above and with standard 10 GA, 12 GA, or 14 GA hole sizes off-the-shelf. Other material/plating combinations and hole sizes are available by special order.

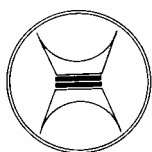

HANLON EQUIPMENT COMPANY  
800 TOUHY AVENUE  
ELK GROVE VILLAGE, ILLINOIS 60007  
PHONE: 847.228.1990 Toll Free: 1-800-HANLONS 426-5667  
FAX: 847.228.1995  
INTERNET: hanlonequipment.com



# WASHERS, CAPS & NUTS

## SPEED CAPPED WASHERS

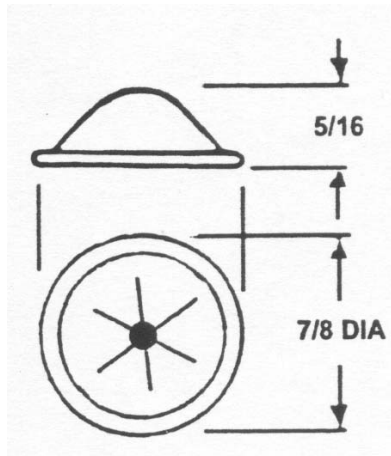

APPLICATION	Designed to permanently lock on to 10, 12, or 14 gauge weld pins or insul-anchors where appearance is a major factor, or where no sharp points or edges are permissible on the surface.
MATERIAL	Decorative Domed Cap - Aluminum Self-Locking Insert - Stainless Steel - "Star" pattern.
COLOR	Plain, bright aluminum. Painted white. Other painted colors are available by special order.

## LACING WASHER AND RING

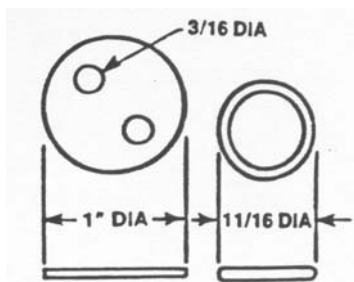

APPLICATION	Designed to be used with lacing wire to wrap insulation around irregular shapes.
MATERIAL	Washer - Aluminum or Stainless Steel Ring - Zinc alloy, bright zinc plated.
NO-AB	Washers are stamped NO AB to indicate non-asbestos material.

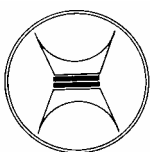

HANLON EQUIPMENT COMPANY  
 800 TOUHY AVENUE  
 ELK GROVE VILLAGE, ILLINOIS 60007  
 PHONE: 847.228.1990 Toll Free: 1-800-HANLONS 426-5667  
 FAX: 847.228.1995  
 INTERNET: hanlonequipment.com



# WASHERS, CAPS & NUTS

## ANNULAR RING CAP FOR USE WITH ANNULAR RING STUDS

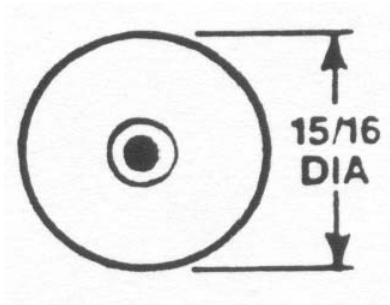
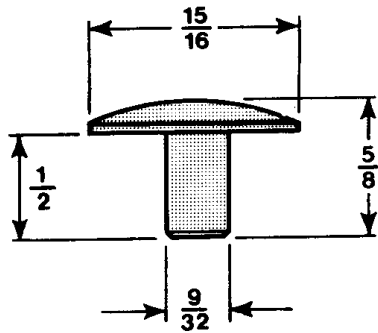

APPLICATION	Designed to permanently lock on to Navy Annular Ring Studs.
MATERIAL	Aluminum
SIZE	For 1/8" or 3/16" Diameter studs.

## KEY HOLE SLOTTED WASHER FOR 3/16" DIAMETER NOTCHED END STUDS

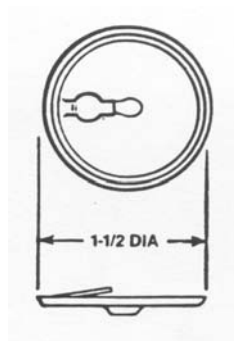

APPLICATION	Designed to permanently lock on to Navy Notched End Studs.
MATERIAL	Mild Steel
PLATING	Cadmium or Galvanized plating available

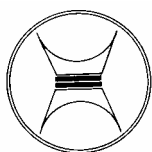

HANLON EQUIPMENT COMPANY  
800 TOUHY AVENUE  
ELK GROVE VILLAGE, ILLINOIS 60007  
PHONE: 847.228.1990 Toll Free: 1-800-HANLONS 426-5667  
FAX: 847.228.1995  
INTERNET: hanlonequipment.com



# WASHERS, CAPS & NUTS

## ANNULAR GROOVE CAP FOR USE WITH ANNULAR GROOVE STUDS

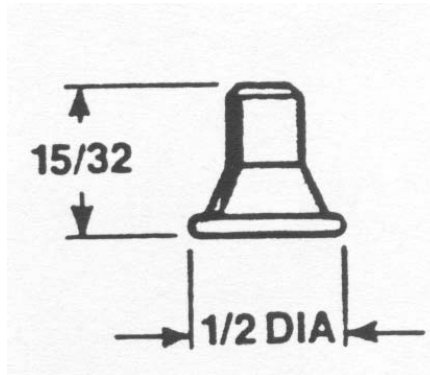

APPLICATION	Designed to permanently lock on to annular groove shoulder studs to hold panel in place against stud shoulder.
MATERIAL	Aluminum
SIZE	For 3/16" Diameter annular groove

## CAP SETTING TOOL FOR INSTALLING WAG AL CAPS

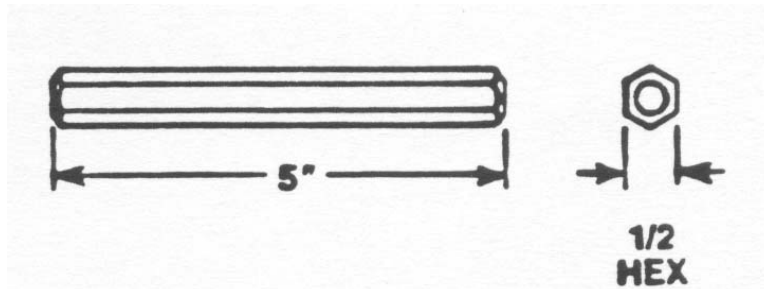

APPLICATION	Designed for installation of the Annular Groove Cap above.
-------------	--

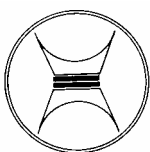

HANLON EQUIPMENT COMPANY  
800 TOUHY AVENUE  
ELK GROVE VILLAGE, ILLINOIS 60007  
PHONE: 847.228.1990 Toll Free: 1-800-HANLONS 426-5667  
FAX: 847.228.1995  
INTERNET: hanlonequipment.com



# WASHERS, CAPS & NUTS

## PANEL NUT FOR 1/4-20 THREADED STUDS

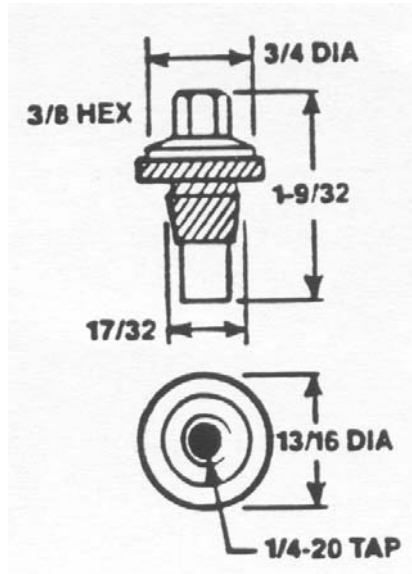

APPLICATION	Designed to be threaded down through pre-drilled holes in panel on to pre-welded studs providing firm, water resistant attachment.
MATERIAL	Aluminum & Neoprene Rubber.
SIZE	For 1/4-20 threaded studs.

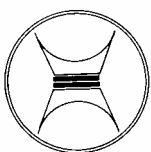

HANLON EQUIPMENT COMPANY  
800 TOUHY AVENUE  
ELK GROVE VILLAGE, ILLINOIS 60007  
PHONE: 847.228.1990 Toll Free: 1-800-HANLONS 426-5667  
FAX: 847.228.1995  
INTERNET: hanlonequipment.com



# WASHERS, CAPS & NUTS

## COMBINATION NUTS

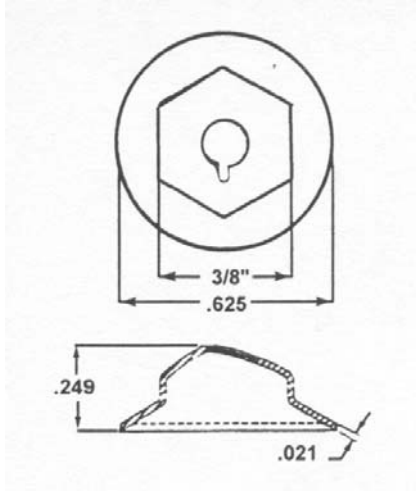

**COMBINATION HEX-NUT  
AND LOCK WASHER "OPEN"**  
FOR 10-24 THREADED STUDS

APPLICATION	For use with 10-24 weld studs. One-piece washer-type locknut combination serving as hex nut, lockwasher and flat washer. Locking design eliminates back-off due to vibration and thermal stress.
MATERIAL	Mild Steel, Zinc Plated
SIZE	For 10-24 threaded studs.

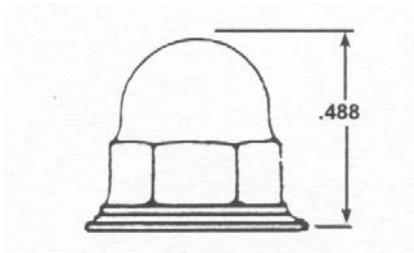

**COMBINATION HEX-NUT  
AND LOCK WASHER "CLOSED"**  
FOR 10-24 THREADED STUDS

APPLICATION	For use with 10-24 weld studs. One-piece washer-type locknut combination serving as hex nut, lockwasher and flat washer. Design encloses fastener when placed on stud.
MATERIAL	Mild Steel, Nickel Plated
SIZE	For 10-24 threaded studs.

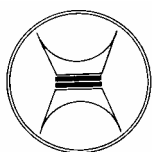

HANLON EQUIPMENT COMPANY  
800 TOUHY AVENUE  
ELK GROVE VILLAGE, ILLINOIS 60007  
PHONE: 847.228.1990 Toll Free: 1-800-HANLONS 426-5667  
FAX: 847.228.1995  
INTERNET: hanlonequipment.com

