

CD STUDS

FLANGED

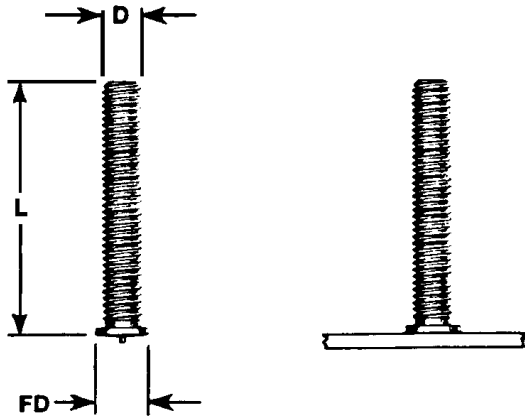

STUD		
D	FD	MIN. L
4-40	.187	.250
6-32	.218	.250
8-32	.250	.250
10-32	.250	.250
10-24	.250	.250
1/4-20	.312	.375
5/16	.375	.500
3/8-16	.437	.500

MATERIAL	LOW CARBON STEEL C - .23% max. P - 0.04% max. Mn - .090% max. S - 0.05% max.	STAINLESS STEEL AISI grade - 302/304/305 Std. Other grades available.
MECHANICAL PROPERTIES	Tensile 60,000 psi (min.) Yield 50,000 psi (min.) Elongation 20% (in 2 inches)	Tensile 85,000 psi (min.) Yield 40,000 psi (min.)
PLATING	Copper plating is standard. Other plating available.	N/A
ANNEALING	Studs are annealed where required.	

MATERIAL	ALUMINUM Alloy - 1100 & 5000 series Other alloys available.	BRASS Alloy - (lead free) 70-30 std. Other alloys available.
MECHANICAL PROPERTIES	Tensile 42,000 psi (min.) 5000 series Yield 30,000 psi (min.) 5000 series	Tensile 70,000 psi (min.) Yield 50,000 psi (min.)

ORDER CODE: CDF

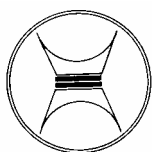

HANLON EQUIPMENT COMPANY
800 TOUHY AVENUE
ELK GROVE VILLAGE, ILLINOIS 60007
PHONE: 847.228.1990 Toll Free: 1-800-HANLONS 426-5667
FAX: 847.228.1995
INTERNET: hanlonequipment.com



FLANGED METRIC

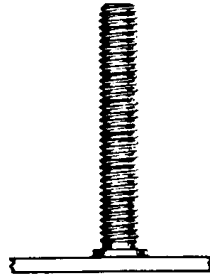
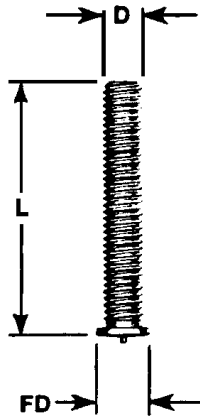

STUD		
D	FD	MIN. L
M2.5 X .45	3.1	6
M3 X .50	4.5	6
M4 X .70	5.5	6
M5 X .80	6.8	8
M6 X 1.00	8	8
M8 X 1.25	9	8

MATERIAL	LOW CARBON STEEL C - .23% max. P - 0.04% max. Mn - .090% max. S - 0.05% max.	STAINLESS STEEL AISI grade - 302/304/305 Std. Other grades available.
MECHANICAL PROPERTIES	Tensile 60,000 psi (min.) Yield 50,000 psi (min.) Elongation 20% (in 2 inches)	Tensile 85,000 psi (min.) Yield 40,000 psi (min.)
PLATING	Copper plating is standard. Other plating available.	N/A
ANNEALING	Studs are annealed where required.	

MATERIAL	ALUMINUM Alloy - 1100 & 5000 series Other alloys available.	BRASS Alloy - (lead free) 70-30 std. Other alloys available.
MECHANICAL PROPERTIES	Tensile 42,000 psi (min.) 5000 series Yield 30,000 psi (min.) 5000 series	Tensile 70,000 psi (min.) Yield 50,000 psi (min.)

ORDER CODE: CDFM

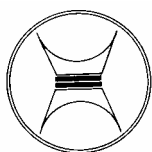

HANLON EQUIPMENT COMPANY
800 TOUHY AVENUE
ELK GROVE VILLAGE, ILLINOIS 60007
PHONE: 847.228.1990 Toll Free: 1-800-HANLONS 426-5667
FAX: 847.228.1995
INTERNET: hanlonequipment.com



SMALL FLANGED

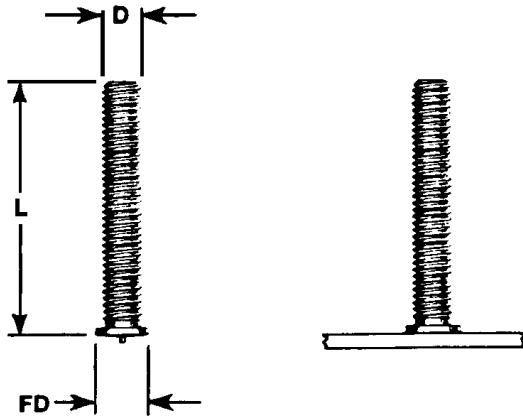

STUD		
D	FD	MIN. L
4-40	.143	.250
6-32	.169	.250
8-32	.195	.250
10-32	.221	.250
10-24	.221	.250
1/4-20	.281	.375
5/16	.342	.500

MATERIAL	LOW CARBON STEEL C - .23% max. P - 0.04% max. Mn - .090% max. S - 0.05% max.	STAINLESS STEEL AISI grade - 302/304/305 Std. Other grades available.
MECHANICAL PROPERTIES	Tensile 60,000 psi (min.) Yield 50,000 psi (min.) Elongation 20% (in 2 inches)	Tensile 85,000 psi (min.) Yield 40,000 psi (min.)
PLATING	Copper plating is standard. Other plating available.	N/A
ANNEALING	Studs are annealed where required.	

MATERIAL	ALUMINUM Alloy - 1100 & 5000 series Other alloys available.	BRASS Alloy - (lead free) 70-30 std. Other alloys available.
MECHANICAL PROPERTIES	Tensile 42,000 psi (min.) 5000 series Yield 30,000 psi (min.) 5000 series	Tensile 70,000 psi (min.) Yield 50,000 psi (min.)

ORDER CODE: CD SF

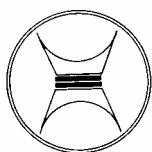

HANLON EQUIPMENT COMPANY
800 TOUHY AVENUE
ELK GROVE VILLAGE, ILLINOIS 60007
PHONE: 847.228.1990 Toll Free: 1-800-HANLONS 426-5667
FAX: 847.228.1995
INTERNET: hanlonequipment.com



NON FLANGED

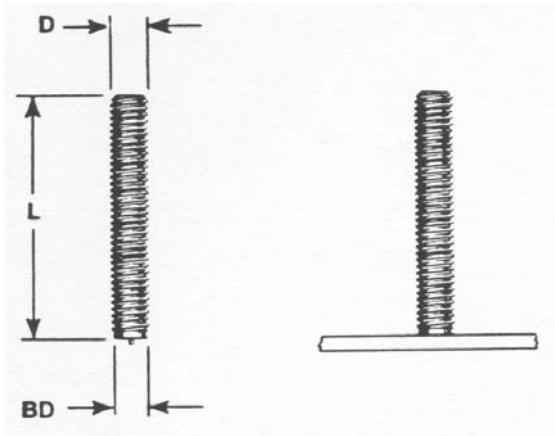

STUD		
D	FD	MIN. L
4-40	.116	.250
6-32	.142	.250
8-32	.168	.250
10-32	.194	.250
10-24	.194	.250
1/4-20	.252	.375
5/16	.315	.500

MATERIAL	LOW CARBON STEEL C - .23% max. P - 0.04% max. Mn - .090% max. S - 0.05% max.	STAINLESS STEEL AISI grade - 302/304/305 Std. Other grades available.
MECHANICAL PROPERTIES	Tensile 60,000 psi (min.) Yield 50,000 psi (min.) Elongation 20% (in 2 inches)	Tensile 85,000 psi (min.) Yield 40,000 psi (min.)
PLATING	Copper plating is standard. Other plating available.	N/A
ANNEALING	Studs are annealed where required.	

MATERIAL	ALUMINUM Alloy - 1100 & 5000 series Other alloys available.	BRASS Alloy - (lead free) 70-30 std. Other alloys available.
MECHANICAL PROPERTIES	Tensile 42,000 psi (min.) 5000 series Yield 30,000 psi (min.) 5000 series	Tensile 70,000 psi (min.) Yield 50,000 psi (min.)

ORDER CODE: CD NF

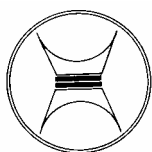

HANLON EQUIPMENT COMPANY
800 TOUHY AVENUE
ELK GROVE VILLAGE, ILLINOIS 60007
PHONE: 847.228.1990 Toll Free: 1-800-HANLONS 426-5667
FAX: 847.228.1995
INTERNET: hanlonequipment.com



FLANGED - NO THREAD

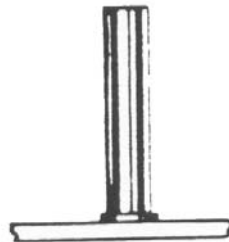
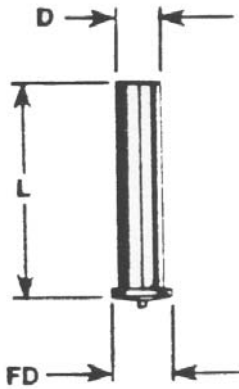

STUD		
D	FD	MIN. L
3/32	.143	.250
.115	.171	.250
1/8	.156	.250
.141	.195	.250
5/32	.221	.250
.161	.221	.250
3/16	.281	.312
.215	.281	.312
1/4	.343	.312
.273	.343	.312
5/16	.343	.500

MATERIAL	LOW CARBON STEEL C - .23% max. P - 0.04% max. Mn - .090% max. S - 0.05% max.	STAINLESS STEEL AISI grade - 302/304/305 Std. Other grades available.
MECHANICAL PROPERTIES	Tensile 60,000 psi (min.) Yield 50,000 psi (min.) Elongation 20% (in 2 inches)	Tensile 85,000 psi (min.) Yield 40,000 psi (min.)
PLATING	Copper plating is standard. Other plating available.	N/A
ANNEALING	Studs are annealed where required.	

MATERIAL	ALUMINUM Alloy - 1100 & 5000 series Other alloys available.	BRASS Alloy - (lead free) 70-30 std. Other alloys available.
MECHANICAL PROPERTIES	Tensile 42,000 psi (min.) 5000 series Yield 30,000 psi (min.) 5000 series	Tensile 70,000 psi (min.) Yield 50,000 psi (min.)

ORDER CODE: CD FNT

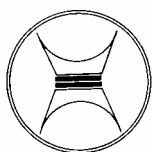

HANLON EQUIPMENT COMPANY
800 TOUHY AVENUE
ELK GROVE VILLAGE, ILLINOIS 60007
PHONE: 847.228.1990 Toll Free: 1-800-HANLONS 426-5667
FAX: 847.228.1995
INTERNET: hanlonequipment.com



SMALL FLANGED - NO THEAD

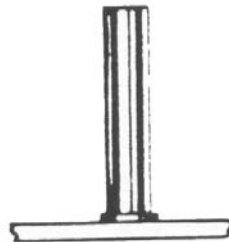
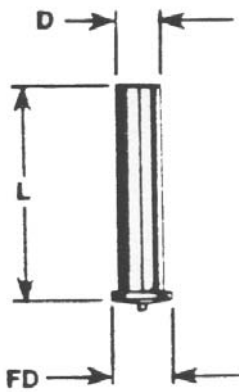

STUD		
D	FD	MIN. L
3/32	.143	.250
.115	.171	.250
1/8	.156	.250
.141	.195	.250
5/32	.221	.250
.161	.221	.250
3/16	.281	.312
.215	.281	.312
1/4	.343	.372
.273	.343	.372
5/16	.343	.500

MATERIAL	LOW CARBON STEEL C - .23% max. P - 0.04% max. Mn - .090% max. S - 0.05% max.	STAINLESS STEEL AISI grade - 302/304/305 Std. Other grades available.
MECHANICAL PROPERTIES	Tensile 60,000 psi (min.) Yield 50,000 psi (min.) Elongation 20% (in 2 inches)	Tensile 85,000 psi (min.) Yield 40,000 psi (min.)
PLATING	Copper plating is standard. Other plating available.	N/A
ANNEALING	Studs are annealed where required.	

MATERIAL	ALUMINUM Alloy - 1100 & 5000 series Other alloys available.	BRASS Alloy - (lead free) 70-30 std. Other alloys available.
MECHANICAL PROPERTIES	Tensile 42,000 psi (min.) 5000 series Yield 30,000 psi (min.) 5000 series	Tensile 70,000 psi (min.) Yield 50,000 psi (min.)

ORDER CODE: CD SFNT

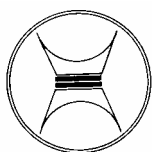

HANLON EQUIPMENT COMPANY
800 TOUHY AVENUE
ELK GROVE VILLAGE, ILLINOIS 60007
PHONE: 847.228.1990 Toll Free: 1-800-HANLONS 426-5667
FAX: 847.228.1995
INTERNET: hanlonequipment.com



NON FLANGED - NO THREAD

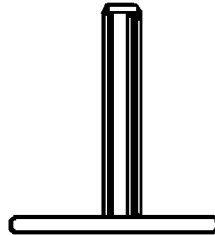
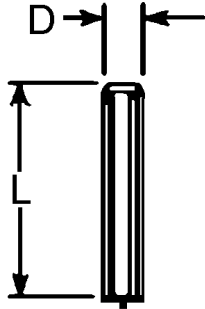

STUD	
D	MIN. L
3/32	.250
.115	.250
1/8	.250
.141	.250
5/32	.250
.161	.250
3/16	.250
.215	.312
1/4	.312
.273	.372
5/16	.500

MATERIAL	LOW CARBON STEEL C - .23% max. P - 0.04% max. Mn - .090% max. S - 0.05% max.	STAINLESS STEEL AISI grade - 302/304/305 Std. Other grades available.
MECHANICAL PROPERTIES	Tensile 60,000 psi (min.) Yield 50,000 psi (min.) Elongation 20% (in 2 inches)	Tensile 85,000 psi (min.) Yield 40,000 psi (min.)
PLATING	Copper plating is standard. Other plating available.	N/A
ANNEALING	Studs are annealed where required.	

MATERIAL	ALUMINUM Alloy - 1100 & 5000 series Other alloys available.	BRASS Alloy - (lead free) 70-30 std. Other alloys available.
MECHANICAL PROPERTIES	Tensile 42,000 psi (min.) 5000 series Yield 30,000 psi (min.) 5000 series	Tensile 70,000 psi (min.) Yield 50,000 psi (min.)

ORDER CODE: CD NFNT

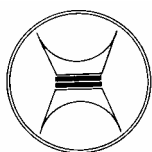

HANLON EQUIPMENT COMPANY
800 TOUHY AVENUE
ELK GROVE VILLAGE, ILLINOIS 60007
PHONE: 847.228.1990 Toll Free: 1-800-HANLONS 426-5667
FAX: 847.228.1995
INTERNET: hanlonequipment.com



DRAWN ARC/STORED ARC

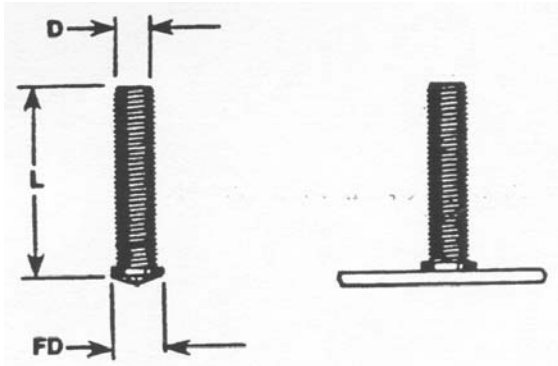

STUD		
D	FD	MIN. L
4-40	.143	.250
6-32	.169	.250
8-32	.195	.250
10-32	.221	.250
10-24	.221	.250
1/4-20	.281	.375
5/16	.375	.500

MATERIAL	LOW CARBON STEEL C - .23% max. P - 0.04% max. Mn - .090% max. S - 0.05% max.	STAINLESS STEEL AISI grade - 302/304/305 Std. Other grades available.
MECHANICAL PROPERTIES	Tensile 60,000 psi (min.) Yield 50,000 psi (min.) Elongation 20% (in 2 inches)	Tensile 85,000 psi (min.) Yield 40,000 psi (min.)
PLATING	Copper plating is standard. Other plating available.	N/A
ANNEALING	Studs are annealed where required.	

MATERIAL	ALUMINUM Alloy - 1100 & 5000 series Other alloys available.	BRASS Alloy - (lead free) 70-30 std. Other alloys available.
MECHANICAL PROPERTIES	Tensile 42,000 psi (min.) 5000 series Yield 30,000 psi (min.) 5000 series	Tensile 70,000 psi (min.) Yield 50,000 psi (min.)

ORDER CODE: CD DA

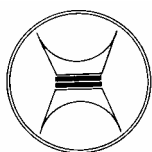

HANLON EQUIPMENT COMPANY
800 TOUHY AVENUE
ELK GROVE VILLAGE, ILLINOIS 60007
PHONE: 847.228.1990 Toll Free: 1-800-HANLONS 426-5667
FAX: 847.228.1995
INTERNET: hanlonequipment.com



DRAWN ARC/STORED ARC

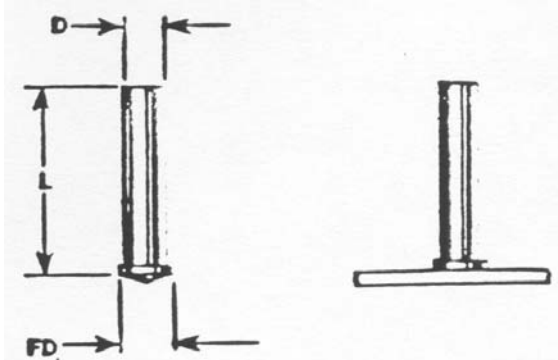

STUD		
D	FD	MIN. L
4-40	.143	.250
6-32	.169	.250
8-32	.195	.250
10-32	.221	.250
10-24	.221	.250
1/4-20	.281	.375
5/16	.315	.500

MATERIAL	LOW CARBON STEEL C - .23% max. P - 0.04% max. Mn - .090% max. S - 0.05% max.	STAINLESS STEEL AISI grade - 302/304/305 Std. Other grades available.
MECHANICAL PROPERTIES	Tensile 60,000 psi (min.) Yield 50,000 psi (min.) Elongation 20% (in 2 inches)	Tensile 85,000 psi (min.) Yield 40,000 psi (min.)
PLATING	Copper plating is standard. Other plating available.	N/A
ANNEALING	Studs are annealed where required.	

MATERIAL	ALUMINUM Alloy - 1100 & 5000 series Other alloys available.	BRASS Alloy - (lead free) 70-30 std. Other alloys available.
MECHANICAL PROPERTIES	Tensile 42,000 psi (min.) 5000 series Yield 30,000 psi (min.) 5000 series	Tensile 70,000 psi (min.) Yield 50,000 psi (min.)

ORDER CODE: CD DANT

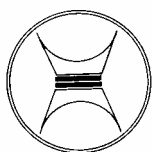

HANLON EQUIPMENT COMPANY
800 TOUHY AVENUE
ELK GROVE VILLAGE, ILLINOIS 60007
PHONE: 847.228.1990 Toll Free: 1-800-HANLONS 426-5667
FAX: 847.228.1995
INTERNET: hanlonequipment.com



TAPPED STUD - NO FLANGE

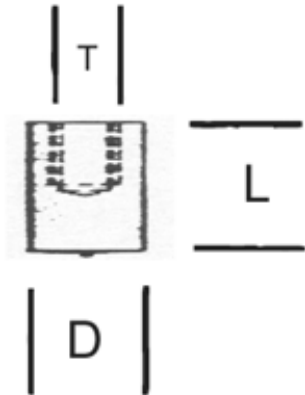

T	D	L
8-32 x maximum depth	5/16 - .3125	19/64 - .2968
6-32 x maximum depth	5/16 - .3125	19/64 - .2968
Stock Stud		

Other tap studs available by special order.

MATERIAL	LOW CARBON STEEL C - .23% max. P - 0.04% max. Mn - .090% max. S - 0.05% max.
MECHANICAL PROPERTIES	Tensile 60,000 psi (min.) Yield 50,000 psi (min.) Elongation 20% (in 2 inches)
PLATING	Copper plating is standard. Other plating available.

ORDER CODE: CD TAP

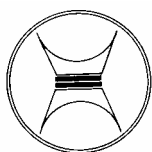

HANLON EQUIPMENT COMPANY
800 TOUHY AVENUE
ELK GROVE VILLAGE, ILLINOIS 60007
PHONE: 847.228.1990 Toll Free: 1-800-HANLONS 426-5667
FAX: 847.228.1995
INTERNET: hanlonequipment.com



BI-METALLIC STUDS

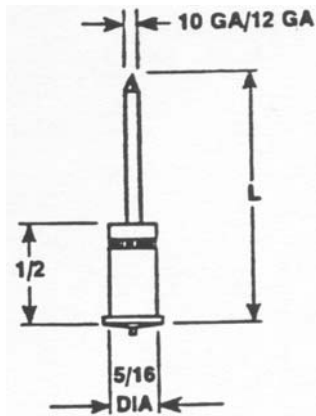

PIN BI-METALLIC STUD

MATERIAL: Pin - 10 gauge (.135dia.) Stainless Steel
12 gauge (.105dia.) Stainless Steel
Base - Aluminum (5000 Series)

WASHERS: Self-locking washers are available. See washer s.

ORDER CODE: BMWP

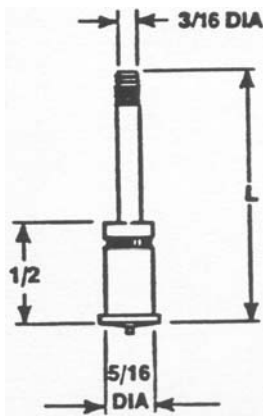

ANNULAR RING STUD

MATERIAL: Pin - Stainless steel
Base - Aluminum (5000 Series)

CAP: The cap for use with this stud is the **WCN AR CAP** annular ring.

ORDER CODE: BMAR

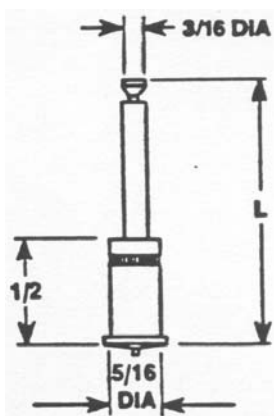

NOTCHED END STUD

MATERIAL: Pin - 10 gauge (.135dia.) Stainless Steel
12 gauge (.105dia.) Stainless Steel
Base - Aluminum (5000 Series)

WASHERS: The washer for this stud is the **WAK** notched end key hole slotted washer.

ORDER CODE: BMNE

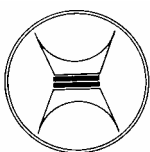

HANLON EQUIPMENT COMPANY
800 TOUHY AVENUE
ELK GROVE VILLAGE, ILLINOIS 60007
PHONE: 847.228.1990 Toll Free: 1-800-HANLONS 426-5667
FAX: 847.228.1995
INTERNET: hanlonequipment.com



FLANGED-ACOUSTICAL HANGER (LAGGING STUD)



STUD						
D	L	FD	HD	HL	W	T
.168	1-1/8	.250	.187	7/8	5/16	1/16
.214	1-1/8	.312	.187	7/8	3/8	5/64

MATERIAL	LOW CARBON STEEL C - .23% max. P - 0.04% max. Mn - .090% max. S - 0.05% max.	STAINLESS STEEL AISI grade - 302/304/305 Std. Other grades available.
MECHANICAL PROPERTIES	Tensile 60,000 psi (min.) Yield 50,000 psi (min.) Elongation 20% (in 2 inches)	Tensile 85,000 psi (min.) Yield 40,000 psi (min.)
PLATING	Copper plating is standard. Other plating available.	N/A
ANNEALING	Studs are annealed where required.	

MATERIAL	ALUMINUM Alloy - 1100 & 5000 series Other alloys available.
MECHANICAL PROPERTIES	Tensile 42,000 psi (min.) 5000 series Yield 30,000 psi (min.) 5000 series

ORDER CODE: CDF AH

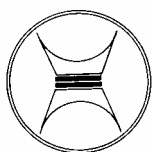

HANLON EQUIPMENT COMPANY
800 TOUHY AVENUE
ELK GROVE VILLAGE, ILLINOIS 60007
PHONE: 847.228.1990 Toll Free: 1-800-HANLONS 426-5667
FAX: 847.228.1995
INTERNET: hanlonequipment.com



SPECIAL CD WELD STUDS

From a .060" diameter no-thread CD stud to a 7/16" hex CD stud, Hanlon can design a special CD stud to meet your precision fastening requirements. The illustrations below indicate just a few of the configurations in which CD studs can be manufactured. These illustrations, however, do not represent any of the standard in-stock product line. If you require a special configuration CD stud for your application, please contact our sales department for assistance. You may submit a sketch or drawing with dimensions and material requirements to Hanlon for a quote.

